

# USER MANUAL

General Information about X-Treme Electric Scooters

Visit: [www.x-tremescooters.com/](http://www.x-tremescooters.com/)

Technical support

visit [www.x-tremescooters.com/technical.html](http://www.x-tremescooters.com/technical.html)

Order parts for your electric scooter

visit: [www.x-tremescooters.com/service.html](http://www.x-tremescooters.com/service.html)

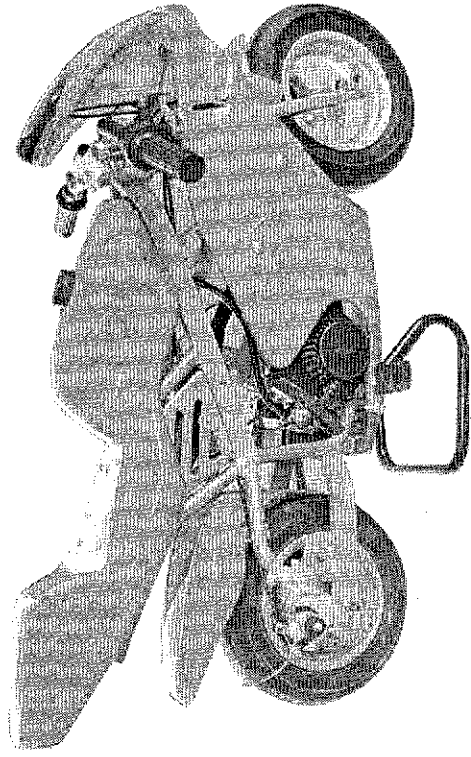

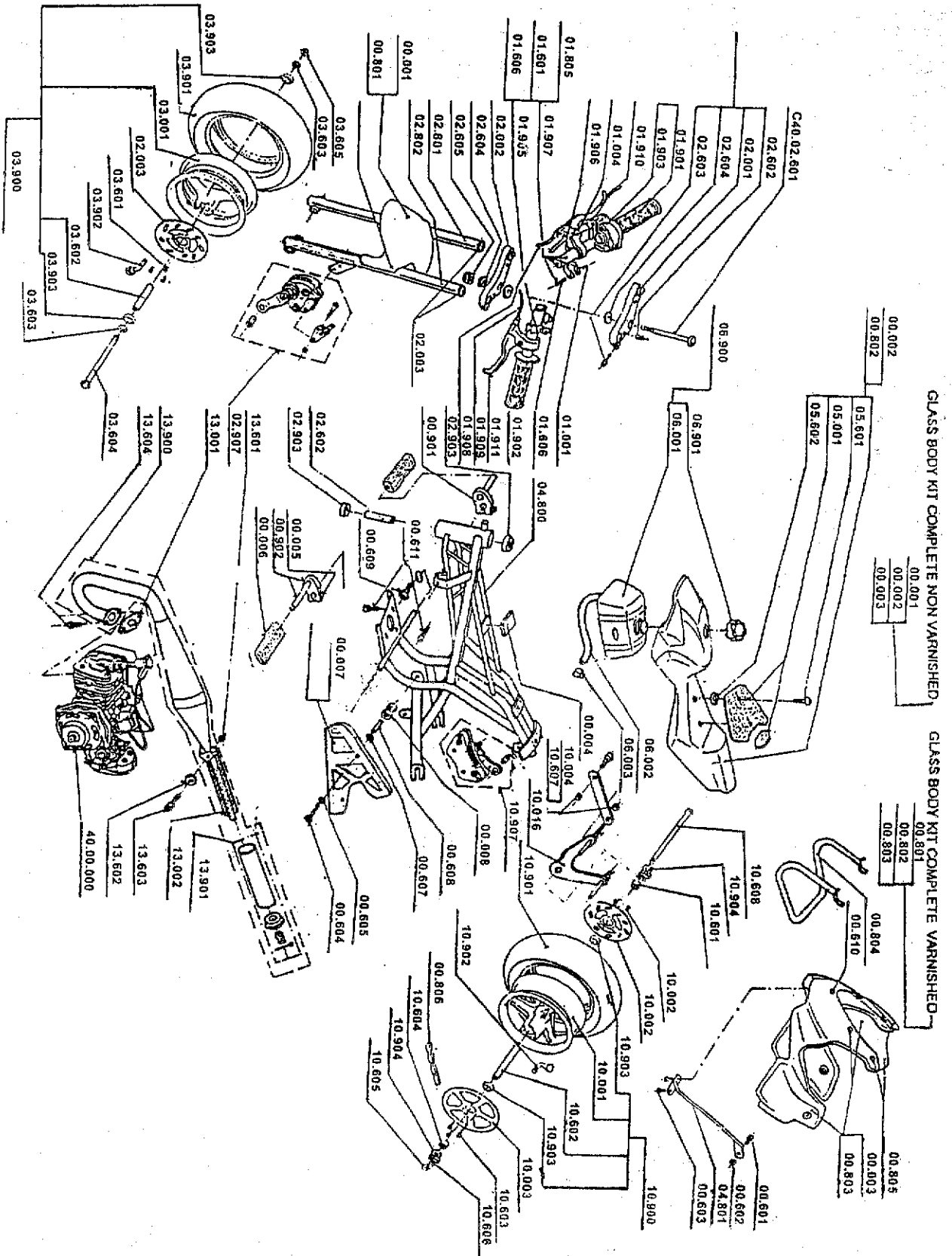

### REPLACEMENT OF TIRE - FIG. 5

Remove the wheel from the minibike. For the front wheel unbolt the brake disk and for the rear wheel, the brake disk and sprocket. Deflate the tire, by removing the valve stem. Place the wheel on a hard surface and press the tire bead from the wheel rim in to the middle relief at centre of rim. Tire is ready to be removed from the rim at this time and is done in the conventional manner. After fitting new Tire and Tube (if necessary) to the rim, you can inflate 28 to 30 psi. Take care to check that the tire bead is fully seated in the rim bead edge. You can now refit the wheel to the bike in reverse order to removing it. Use Caution and recheck your work always.

### DISMANTLING AND MOUNTING OF AIR FILTER - FIG. 3

Dismantling the air filter unscrew 2 and so ease the holder and put down the suction chamber 1. On this way you gain access to the filter, that you can take off by means of screw driver. After cleaning and lubricating it with engine oil proceed the assembly on a reverse sequence.

### WHAT TO DO BEFORE A PERIOD OF IDLENESS:

Should the minibike not be used for a more or less longer period, take care and make measure as follows:

- Remove petrol from the fuel tank
- Store the minibike on a smooth and dry place
- Protect it from dust
- Remove the spark plug, clean it, put some drops of fuel with oil into the cylinder, pull 2-3 times the starter rope to distribute oil drops and then screw-in the spark plug.

Thank you for your selection of our product. Our wish is that the Minibike may serve you a long time and trouble-free, contribute to your satisfaction and bring you a pleasure.

## MINIBIKE-PMI

SERVICE MANUAL FOR USE AND MAINTENANCE AND SPARE PARTS LIST  
For your own safety and the safety of others Follow these recommendations in order to use your MINIBIKE safely and correctly. Read the instructions CAREFULLY, failure to do so may place yourself and others in extreme and or ultimate DANGER. If you do not understand the instructions and Data then, you are not to attempt to operate this Minibike under any circumstances. It may be used for show purposes only!

### CONTENTS

INTRODUCTION.....	PAGE
TECHNICAL DATA .....	2
UNPACKING AND SETTING UP BEFORE RIDING .....	2
SAFETY .....	3
BEFORE STARTING.....	3
STARTING THE ENGINE - FIG. 2.....	4
CARBURETOR - FIG. 3 .....	4
RIDING .....	4
PERIODIC MAINTENANCE .....	5
CHAIN SETTING AND MAINTENANCE .....	5
CENTRIFUGAL CLUTCH REPAIR OR REPLACEMENT.....	5
BRAKES ADJUSTING - FIG. 4.....	6
FRONT BRAKES PADS REPLACEMENT - FIG. 7.....	6
REAR BRAKES PADS REPLACEMENT - FIG. 7.....	6
REMOVE AND REFIT THE FRONT WHEEL - FIG. 5.....	7
REMOVE AND REFIT THE REAR WHEEL - FIG. 5.....	7
REPLACEMENT OF SPROCKET - FIG. 9 .....	7
ENGINE .....	8
MINIBIKE SQ40A - FIG. 5 .....	9,10
PARTS LIST.....	11,12
FRONT AND REAR BRAKES - FIG. 7 .....	13
REPLACEMENT OF TIRE - FIG. 5 .....	14
DISMANTLING AND ASSEMBLY OF AIR FILTER-FIG.3 .....	14
WHAT TO DO BEFORE A PERIOD OF IDLENESS .....	14



UNPACKING AND SETTING UP BEFORE RIDING

The minibike is delivered in a cardboard carton and packed with folded handlebars and brake levers. After unpacking, set up the handlebars into the position, that suits the best for driving. The maximum pulled brake lever position should not touch on the handlebar grip. After setting up, tighten the handlebar nuts 1, brake lever bolts 2, and the throttle assy. Bolts. See, Fig. 1. The level of foot rest's can be regulated by loosening the bolt M5 (914.003.01) on the handle of the foot rest (439.001.01). The foot rest can be moved to the front or back position. It is recommended to try and check the position of handlebars and foot rest's individually. While tightening the bolts and nuts, do not use an excessive force as to not damage the threads, or distort the tubes and other parts. Verify the smooth and perfect function of the Bowden cables to throttle and both brakes. Fill the fuel tank with fuel. (Gas-oil mix) Failure to use the proper oil mix ratio will result in Engine damage for which you will be responsible.

Fig. 1

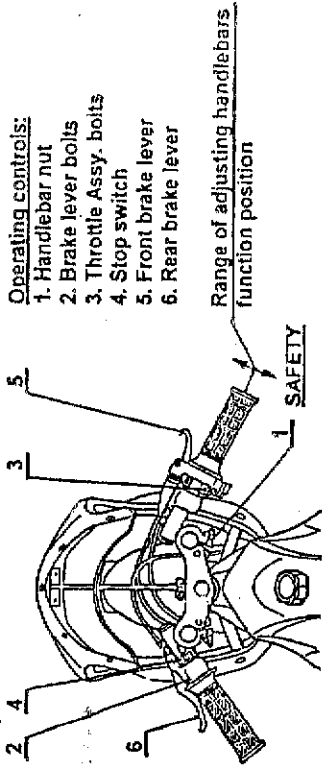

Operating controls:

1. Handlebar nut
2. Brake lever bolts
3. Throttle Assy. bolts
4. Stop switch
5. Front brake lever
6. Rear brake lever

Range of adjusting handlebars function position

The minibike is unsuitable for public road use. It does not comply with valid Safety Standards. Unsafe and careless use of a minibike can result in serious injuries. The driver can minimize the potential risks by wearing the Safety Equipment. The driver must wear safety helmet, goggles, gloves, elbow pads, kneepads, and firm footwear. The minibike cannot be used on wet, icy or oily surfaces. Avoid uneven surfaces and obstacles. Drive with two hands on the handlebars.

BEFORE STARTING

It is strongly recommended to follow all the instructions about the break-in period to promote engine reliability and long life. Break-in period of the minibike is complete after the consumption of five full fuel tanks. It is important to use petrol 91 or 92 Octane fuel with synthetic oil in the ratio 25:1 and after break-in period a ratio of 50:1. Mix the gas and oil completely before putting it into the fuel tank. During the break-in period do not run the engine at maximum RPM and do not allow the engine to overheat. Check the tire inflation - 200 kPa (2 bars) or (28 to 30psi) to be commensurate with the driver's weight. The ~~tire~~ pressure should never exceed 2,5 bars, (38psi) in either the front or rear wheel.

*to be*

C40.10.002	SCREW M 5 x 16	107.001.01	NUT M 5
C40.00.015	SCREW M 5 x 20	C40.13.601	SCREW M 5
E40.005.01	SCREW M 5 x 30	107.008.01	NUT M 5 SELF-LOCKING
C40.00.611	SCREW M 6 x 16	C40.10.001	NUT M 6 SELF-LOCKING
C40.13.603	SCREW M 6 x 20	C40.01.601	NUT M 8 SELF-LOCKING
E40.009.01	SCREW M 6 x 22	C40.03.105	NUT M 10 SELF-LOCKING
E40.010.01	SCREW M 6 x 25	E40.012.01	NUT M 8 LEFT
E40.011.01	SCREW M 6 x 32	40.003.01	WASHER 10.5
E40.001.01	SCREW M 4 x 8	40.010.00	WASHER 8.4
E40.004.01	SCREW M 4 x 10	40.011.00	WASHER 8.1
E40.005.01	SCREW M 6 x 16	107.001.00	RIVET 4 x 8
E40.016.05.02	SCREW M 5 x 25	107.006.00	ROLLER 6 x 6
		40.003.00	WOODRUFF KEY 3.7 x 3.7
		40.005.00	WOODRUFF KEY 2.7 x 3.7
		40.007.00	LOCK 15
		40.008.00	LOCK 35
		40.010.00	PISTON PIN LOCK RING
		960.003.00	BEARING 6000 2R
		960.004.00	BEARING 6200 2R
		40.006.00	BEARING 6202 C3
		40.007.00	BEARING 6202 2ZR
		40.001.00	PACKUNG RING 12 x 22 x 7
		40.002.00	PACKUNG RING 15 x 26 x 7

- C40.01.004 BOWDENCUST GUARD
- C40.02.003 CAP
- C40.02.001 HAT
- C40.01.905 GAS CABLES/LEVE ASSY
- C40.01.907 THROTTLE TWIST GRIP
- C40.01.907 THROTTLE TWIST GRIP
- C40.02.802 FORK WITH BRAKE HOLDER
- C40.02.801 RIGHT FORK
- C40.02.001 FORKS HOLDER ABOVE-COMLETE (W 130)
- C40.02.002 FORKS HOLDER BELOW-COMLETE (W 130)

- TRANSMISSION
- C40.10.003 SPROCKET 66 TEEHII
- C40.00.806 CHAIN 140 LINKS

ELECTRIC COMPONENTS

- E40.003.00 SPARK PLUG
- E40.002.00 MOTOR COMPLETE
- E40.001.00 IGNITION COMPLETE
- E40.005.00 SPARK PLUG CAP
- C40.01.905 KILL SWITCH

OTHER PARTS

- C40.00.608 SPACER C25 8
- C40.00.007 CHAIN ROLLER
- C40.06.003 GAS TANK WITH CAP
- C40.06.003 GAS TANK W/O CAP
- C40.06.301 GAS TANK CAP
- C40.00.004 RUBBER FRAME PAD
- C40.00.804 STAND
- C40.00.607 WASHER 6.4 x 18 x 1
- C40.05.001 RUBBER SEAT
- C40.16.002 FUEL HOSE
- C40.06.003 HOSE CLAMP 11/7
- C40.13.602 WASHER
- C40.00.901 ADJUSTABLE FOOT REST-RIGHT
- C40.00.902 ADJUSTABLE FOOT REST-LEFT
- C40.00.006 FOOT PEGS PLASTIC-PAIR

JOINING ELEMENTS

- C40.02.601 SCREW M 10 x 140
- C40.107 SCREW M 5 x 25
- C40.03.601 SCREW M 5 x 16
- C40.01.606 SCREW M 8 x 35

INTRODUCTION

The Minibike -SQ40A is designed and built for use on a paved closed circuit track. The track should be clean and without obstacles of any kind. Qualified adults and younger persons can drive the minibike. Children can drive the minibike only under the supervision of a responsible adult person. The minibike is constructed especially for racing competitions on special racing tracks.

The minibike uses a single-cylinder two-stroke, Gasoline combustion engine, and has an air filter and exhaust silencer. Transfer of power to the rear wheel is through a drive chain. The the overall drive ratio to the rear wheel is changed by the replacement of chain sprockets. The front and rear wheel is equipped with disk brakes. The rear brake is controlled with the left lever and the front brake is controlled with the right lever on the handlebars.

BASIC TECHNICAL DATA

ENGINE: MT-A1 ..... TWO-STROKE  
 NUMBER OF CYLINDERS ..... 1  
 SIZE, CAPACITY ..... 45cc 49cc  
 ENGINE COOLING SYSTEM ..... AIR COOLED  
 POWER OUTPUT ..... 2.5kW at 8700rpm

CARBURETOR ..... DELL'ORTO  
 FUEL ADMISSION ..... REED VALVE DIRECT TO CRANKCASE  
 IGNITION ..... ELECTRONIC  
 SPARK PLUG ..... NGK B9 ES  
 STARTING ..... HAND PULL TYPE, MANUAL  
 CLUTCH ..... CENTRIFUGAL, FRICTION

FRAME: WELDED ..... HIGH STRESS STEEL TUBES  
BRAKES: FRONT WHEEL ..... DISC BRAKES  
 REAR WHEEL ..... MECHANICAL BRAKES  
WHEELS: FRONT ..... OF LIGHT ALLOY 6.5" - 63  
 REAR ..... OF LIGHT ALLOY 6.5" - 63  
TIRE: FRONT ..... SIZE 90/65 - 6.5"  
 REAR ..... 110/50 - 6.5", 90/65 - 6.5"  
FUEL: PETROL (GASOLINE) ..... OCTANE 92 + SYNTHETIC OIL  
 MIXING RATIO (after break in period) ..... 50:1  
 TANK CAPACITY ..... 1 Liter  
 SPEED: WITH THE INSTALLED RATIO: ..... up to 28 mph(45 km/h)

UNLOADED WEIGHT: ..... (45lbs.) 19 kg  
CARRYING CAPACITY: ..... (240lbs) 110 kg  
BASIC DIMENSIONS:  
 LENGTH ..... 950 mm  
 WIDTH ..... 500 mm  
 HEIGHT ..... 565 mm

C40.02.907 - FRONT BRAKE COMPLETE

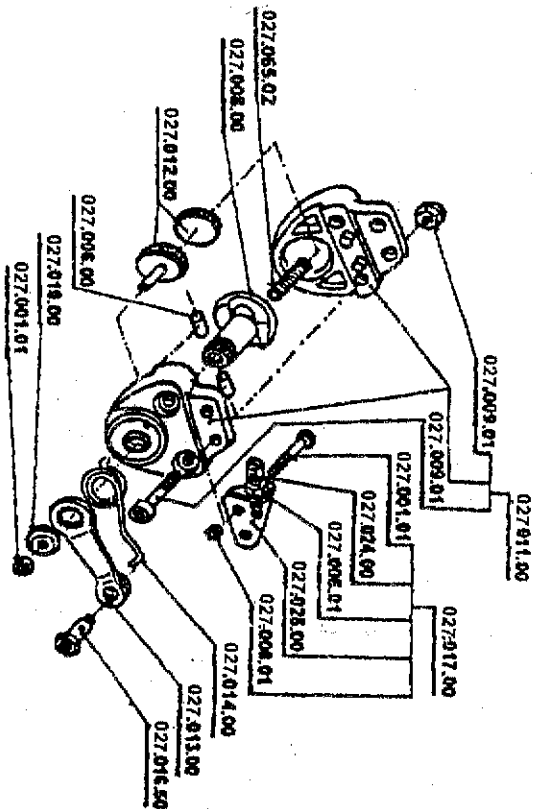

C40.10.907 - REAR BRAKE COMPLETE

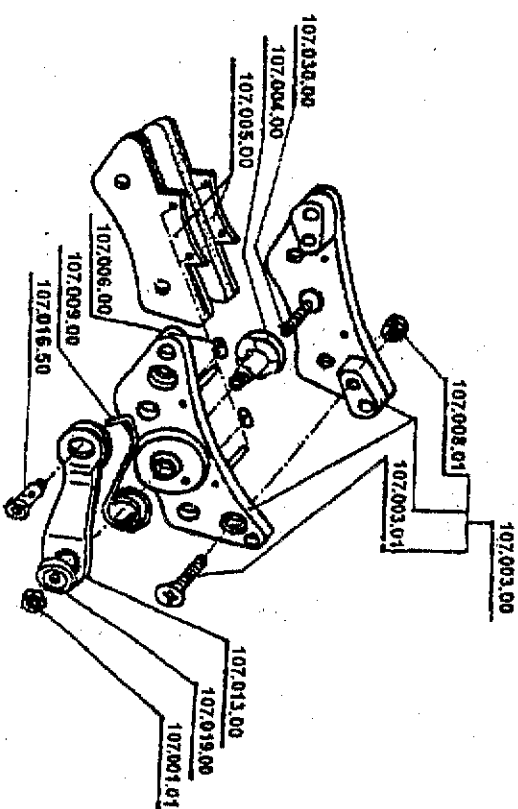

FIG. 7

**PERIODIC MAINTENANCE**

Periodic maintenance is the best way to help the machine perform well, give longevity and provide safety and low cost operation. In addition, you will be spared [redacted] from self caused problems, resulting from poor maintenance or no maintenance.

**A. Before every ride:**

1. Check the Cables and efficiency of brakes.
2. Check the lubrication and chain tension settings. The chain free play should be (5 mm) (.200in) After every ride clean the minibike carefully and keep it clean. Do not use aggressive cleaning detergents.
3. After 1-hour of use, wash the air filter [redacted] and lubricate it with special oil for air filters.
4. After 1- hour of use, check the state of the clutch pads. Review the clutch adjustment.

**B. After every 5 hours of riding:**

5. Check the tightness of all bolts and nuts. Tighten carefully to prevent damage to other parts.
  6. Wash the air filter in gas and lubricate it with special oil for an air filters to better catch the dust.
  7. Clean carefully the carburetor float chamber.
  8. Check the brake pads, the thickness of brake lining cannot be less than 1 mm (.039 in). Review the basic brake adjustment.
  9. Check the state of the clutch pads. - the thickness cannot be less than 1 mm (.039in). Review the clutch adjustment.
- C. Every time after 10 hours of riding:**
10. Check the state of the clutch pads - the thickness cannot be less than 1 mm (.039in).

**CHAIN SETTING AND MAINTENANCE**

To set the chain tension, loosen the Nut (920.011.01) of the axel thru the rear wheel and the nut (914.021.01) of the rear Caliper anchor plate. The required chain tension (chain free play ) is (5 mm) (.200in) and is performed by equal movement of the Axel adjustor plate (920.009.01) on the both sides of the rear wheel. When the adjustment is correct, tighten the Axel nuts and the Caliper holding nut. Tighten the adjustor plate nuts both sides an extra nip, just to set them firmly. It is important to lubricate the chain regularly, to avoid excess wear and prolong effective lifetime. The lubrication is important after every ride on a wet surface. It is recommended to lubricate the minibike with special chain spray. If chain replacement is necessary, check both chain Sprockets and if there is a need to change them do it together with the chain.

**CENTRIFUGAL CLUTCH PARTS REPLACEMENT**

Remove the chain guard by loosening two bolts M6 (916.020.01), Fig. 5. Loosen the chain and remove it from the sprocket. Next, loosen three bolts holding the aluminum clutch housing. Remove it together with steel clutch basket, and dismantle it. Loosen the bolt from the carrier and remove the clutch from the engine. Loosen and remove the adjustable bolts and springs. Then dismantle the safety rings from pins. When all this is done, replace with new clutch slipper shoes and springs (if required), at this time. During the reassembly process follow these steps: 1. put the plate with the springs on the slipper shoes. 2. Put the plate against the carrier and mount it on the fixed pins. Fit it with the safety rings and install the adjustable bolts.

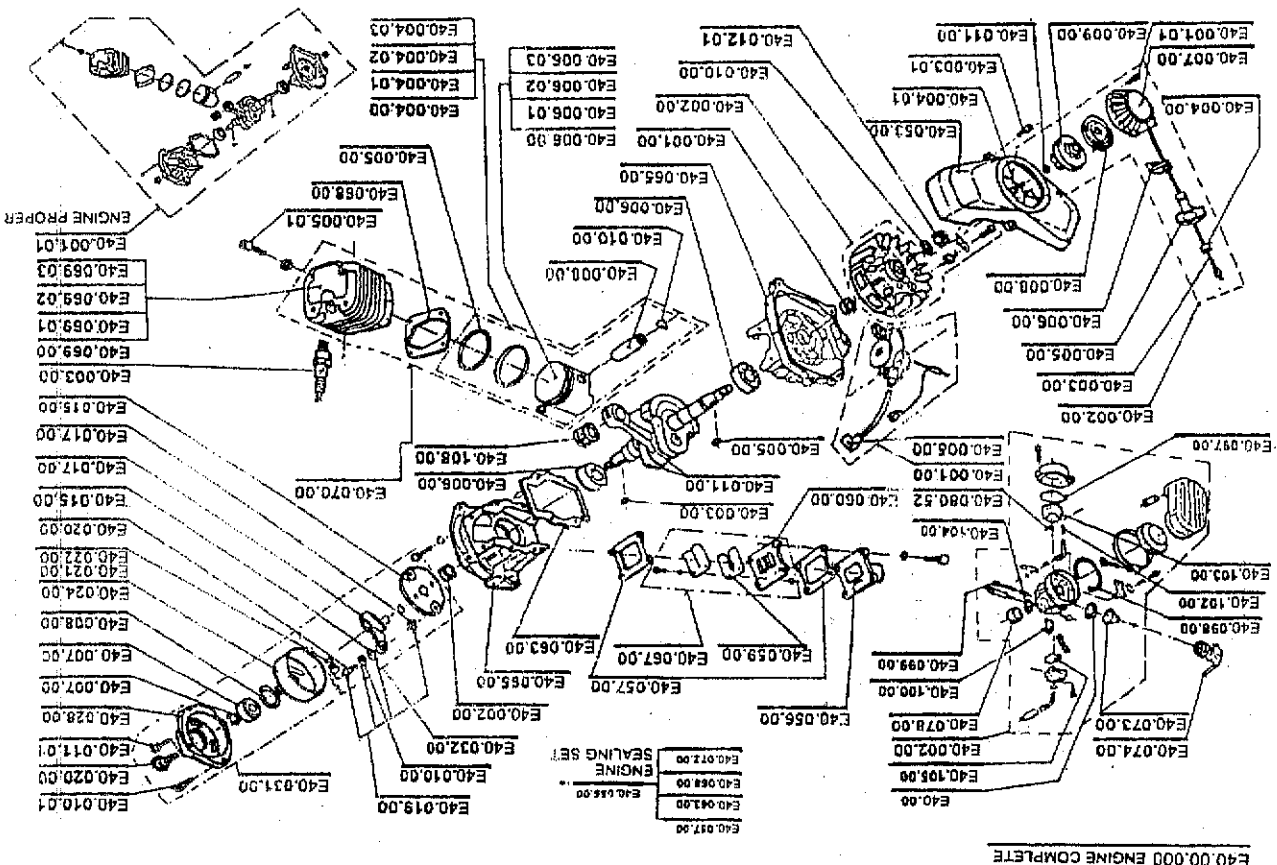

## STARTING THE ENGINE

To be done only on the starting stand - Fig. 2. After opening the tank filling hole, fill the tank with fuel and close it by screwing-in cap. Open the petrol supply cock by turning the small lever into position "ON", Fig. 3. Set the choke lever into position "C", Fig. 3. Without turning the accelerating handle, pull gently twice the starting wire and by next quick pull start the engine. It is not allowed to pull the starting wire up to full winding off. After a short engine run, put the choke lever back to position "A" and let the engine run about 1 min. Let the Minibike on the starting stand and, if need be, adjust the no-load speed to such a rate lest coupling should take along the rear wheel. For adjustment use the adjustment screw № 4 on the carburetor, Fig. 3.



Fig. 2

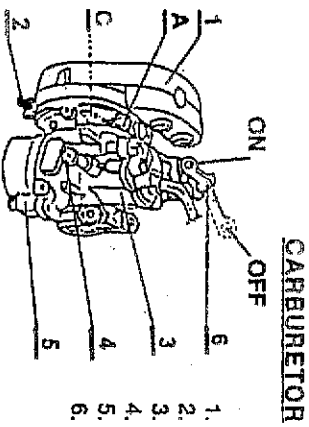

Fig. 3

1. Suction chamber
2. Sleeve screw
3. Carburetor body
4. Adjusting screw of no-load run
5. Float chamber
6. Fuel cock

## RIDE

After mounting the Minibike and slow turning the acceleration handle, you are starting your ride. Before braking, turn back the acceleration handle and depress slightly the front brake lever and then the rear brake lever. Beware of the wheels not to get them in skid.

The Minibike engine will be switched off by pushing the push-button of the stop switch on handlebars. After the first half-hour ride it is necessary to check the tightening of screws and nuts, especially of the engine. Check also the brake setting.

E40.00.000	MINIBIKE	E40.009.00	STARTER SPRING
E40.001.01	ENGINE COMPLETE	E40.009.00	RATCHET WHEEL
E40.002.00	ENGINE PROPER	E40.011.00	WASHER 4.5 x 16 x 1.5
E40.004.00	CARBURETOR SHA. #12L	E40.015.00	WASHER 9.1 x 16 x 1
E40.004.01	PISTON COMPLETE - A	E40.017.00	WASHER 6.1 x 16 x 1.5
E40.004.02	PISTON COMPLETE - B	E40.020.00	FINION
E40.004.03	PISTON COMPLETE - C	E40.108.00	CONNECTING ROD BEARING
E40.005.00	PISTON COMPLETE - D		
E40.006.00	PISTON RING		
E40.006.01	PISTON - A		
E40.006.02	PISTON - B		
E40.006.03	PISTON - C		
E40.008.00	PISTON - D		
E40.011.00	WRIST - PIN		
E40.015.00	CRANK BALANCED		
E40.017.00	CLUTCH DISC		
E40.019.00	CLUTCH LEVER - 2 PCS		
E40.020.00	CLUTCH SCREW COMPLETE		
E40.021.00	CLUTCH SCREW SCREW		
E40.022.00	CLUTCH SPRING - SERIE 1.25 - 2 PCS		
E40.024.00	CLUTCH SPRING - RACING 1.4 - 2 PCS		
E40.028.00	CLUTCH DRUM		
E40.031.00	CLUTCH CASE		
E40.032.00	CLUTCH CASE COMPLETE		
E40.033.00	ENGINE COVERING		
E40.034.00	ENGINE SEALING SET		
E40.035.00	FLANGE		
E40.037.00	DIAPHRAGM SEALING - 2 PCS		
E40.039.00	DIAPHRAGM		
E40.040.00	DIAPHRAGM WASHER		
E40.043.00	SEALING ENGINE BLOCK		
E40.045.00	DIAPHRAGM COMPLETE		
E40.046.00	SEALING		
E40.049.00	CYLINDER - A		
E40.050.00	CYLINDER - B		
E40.051.00	CYLINDER - C		
E40.052.00	CYLINDER - D		
E40.053.00	CYLINDER + PISTON COMPLETE		
E40.054.00	EXHAUST SEALING		
E40.055.00	PLASTIC CONNECT. FUEL COCK		
E40.056.00	FUEL COCK		
E40.057.00	EXHAUST COMPLETE		
E40.058.00	EXHAUST SILENCER COMPLETE		
E40.059.00	SILENCER/MASS		
E40.060.00	JET 52		
E40.061.00	FLLOAT CHAMBER SEALING		
E40.062.00	CARBURETOR SEALING 1		
E40.063.00	ADJUSTING SCREW		
E40.064.00	TROTTLE VALVE		
E40.065.00	CARBURETOR FILTER		
E40.066.00	NEEDLE VALVE		
E40.067.00	FLLOAT		
E40.068.00	CARBURETOR SEALING 2		
E40.069.00	TROTTLE VALVE SEALING		
E40.070.00	LET SET		
E40.071.00	STARTER COMPLETE		
E40.072.00	STARTER ROPE		
E40.073.00	HOLDER		
E40.074.00	GUIDE		
E40.075.00	GUIDE BUSH		
E40.076.00	STARTER CASE		
E40.077.00	STARTER CASE		
E40.078.00	STARTER CASE		
E40.079.00	STARTER CASE		
E40.080.00	STARTER CASE		
E40.081.00	STARTER CASE		
E40.082.00	STARTER CASE		
E40.083.00	STARTER CASE		
E40.084.00	STARTER CASE		
E40.085.00	STARTER CASE		
E40.086.00	STARTER CASE		
E40.087.00	STARTER CASE		
E40.088.00	STARTER CASE		
E40.089.00	STARTER CASE		
E40.090.00	STARTER CASE		
E40.091.00	STARTER CASE		
E40.092.00	STARTER CASE		
E40.093.00	STARTER CASE		
E40.094.00	STARTER CASE		
E40.095.00	STARTER CASE		
E40.096.00	STARTER CASE		
E40.097.00	STARTER CASE		
E40.098.00	STARTER CASE		
E40.099.00	STARTER CASE		
E40.100.00	STARTER CASE		
E40.101.00	STARTER CASE		
E40.102.00	STARTER CASE		
E40.103.00	STARTER CASE		
E40.104.00	STARTER CASE		
E40.105.00	STARTER CASE		
E40.106.00	STARTER CASE		
E40.107.00	STARTER CASE		
E40.108.00	STARTER CASE		
E40.109.00	STARTER CASE		
E40.110.00	STARTER CASE		
E40.111.00	STARTER CASE		
E40.112.00	STARTER CASE		
E40.113.00	STARTER CASE		
E40.114.00	STARTER CASE		
E40.115.00	STARTER CASE		
E40.116.00	STARTER CASE		
E40.117.00	STARTER CASE		
E40.118.00	STARTER CASE		
E40.119.00	STARTER CASE		
E40.120.00	STARTER CASE		
E40.121.00	STARTER CASE		
E40.122.00	STARTER CASE		
E40.123.00	STARTER CASE		
E40.124.00	STARTER CASE		
E40.125.00	STARTER CASE		
E40.126.00	STARTER CASE		
E40.127.00	STARTER CASE		
E40.128.00	STARTER CASE		
E40.129.00	STARTER CASE		
E40.130.00	STARTER CASE		
E40.131.00	STARTER CASE		
E40.132.00	STARTER CASE		
E40.133.00	STARTER CASE		
E40.134.00	STARTER CASE		
E40.135.00	STARTER CASE		
E40.136.00	STARTER CASE		
E40.137.00	STARTER CASE		
E40.138.00	STARTER CASE		
E40.139.00	STARTER CASE		
E40.140.00	STARTER CASE		
E40.141.00	STARTER CASE		
E40.142.00	STARTER CASE		
E40.143.00	STARTER CASE		
E40.144.00	STARTER CASE		
E40.145.00	STARTER CASE		
E40.146.00	STARTER CASE		
E40.147.00	STARTER CASE		
E40.148.00	STARTER CASE		
E40.149.00	STARTER CASE		
E40.150.00	STARTER CASE		
E40.151.00	STARTER CASE		
E40.152.00	STARTER CASE		
E40.153.00	STARTER CASE		
E40.154.00	STARTER CASE		
E40.155.00	STARTER CASE		
E40.156.00	STARTER CASE		
E40.157.00	STARTER CASE		
E40.158.00	STARTER CASE		
E40.159.00	STARTER CASE		
E40.160.00	STARTER CASE		
E40.161.00	STARTER CASE		
E40.162.00	STARTER CASE		
E40.163.00	STARTER CASE		
E40.164.00	STARTER CASE		
E40.165.00	STARTER CASE		
E40.166.00	STARTER CASE		
E40.167.00	STARTER CASE		
E40.168.00	STARTER CASE		
E40.169.00	STARTER CASE		
E40.170.00	STARTER CASE		
E40.171.00	STARTER CASE		
E40.172.00	STARTER CASE		
E40.173.00	STARTER CASE		
E40.174.00	STARTER CASE		
E40.175.00	STARTER CASE		
E40.176.00	STARTER CASE		
E40.177.00	STARTER CASE		
E40.178.00	STARTER CASE		
E40.179.00	STARTER CASE		
E40.180.00	STARTER CASE		
E40.181.00	STARTER CASE		
E40.182.00	STARTER CASE		
E40.183.00	STARTER CASE		
E40.184.00	STARTER CASE		
E40.185.00	STARTER CASE		
E40.186.00	STARTER CASE		
E40.187.00	STARTER CASE		
E40.188.00	STARTER CASE		
E40.189.00	STARTER CASE		
E40.190.00	STARTER CASE		
E40.191.00	STARTER CASE		
E40.192.00	STARTER CASE		
E40.193.00	STARTER CASE		
E40.194.00	STARTER CASE		
E40.195.00	STARTER CASE		
E40.196.00	STARTER CASE		
E40.197.00	STARTER CASE		
E40.198.00	STARTER CASE		
E40.199.00	STARTER CASE		
E40.200.00	STARTER CASE		



## ADJUSTING THE BRAKES

Fig. 4

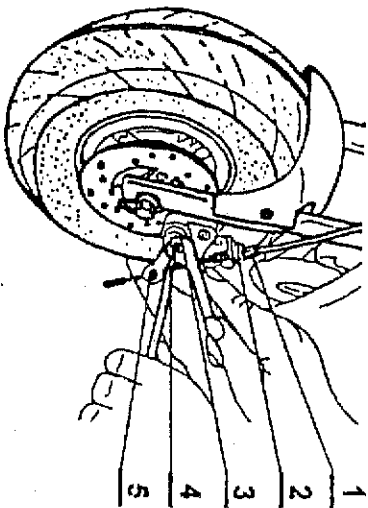

### Fine brake adjusting:

Fine brake adjustment can be carried out on both ends of brake bowden wire by means of the screw 1 and nut 2.

### Basic brake adjusting:

It is carried out in such a way, at first, the nut 2 will be loosened and the screw 1 of fine tuning screwed-in. Loosen the locking nut 3 and tighten the adjusting screw 4 so that the wheel can be free turned. Tighten the locking nut 3.

*Don't release the wire catcher 5!*

## FRONT BRAKE PADS REPLACEMENT: FIG. 7

At first, loosen the nut 920.006.01 of fine front brake adjustment. Screw - in fully the screw. Unscrew maximum the adjusting screw and lock it by fine tightening the nut 920.001.01. Dismantle the front wheel. Unscrew the nuts 920.008.01 on the front brake and remove the screws 911.001.01. Unscrew two screws 914.009.01 from the side of control lever on brake body and separate both bodies 512.011.00 each other. Remove the old brake pads from both parts. Slide the brake plate, fitted with pin, into the part with operating mechanism. Force on carefully the brake plate into the opposite piece. Before reassembly clean the whole brake. Assembly follows in reverse sequence.

## REAR BRAKE PADS REPLACEMENT: FIG. 7

Before replacing the rear brake lining it is necessary to loosen the nut 920.006.01 of fine adjustment of rear brake. Screw-in fully the screw of fine adjustment. Loosen the nut 920.001.01 of basic adjustment. Unscrew maximum the adjustment screw 112.030.00 and lock it by fine tightening the nut 920.001.01. Don't release the wire catcher 512.016.00 and dismantle the rear wheel. Shift the whole brake out of the guide pins. Unscrew both screws 912.003.01 from the control lever side. Separate both bodies 112.003.00 each other and shift the worn-out brake plates out of guide pins clean carefully the brake and put the new brake plates on the guide pins so that they face by lining towards themselves. The assembly follows in a reverse way. After mounting the rear wheel carry out the chain adjustment and basic brake adjustment.

## REMOVE AND REPLACE THE FRONT WHEEL - FIG. 5

Before dismantling the front wheel it is necessary to remove the front brake pads from the front brake, so it is possible to move the brake caliper from the wheel and be able to draw out the wheel and tire. Remove the front axle nut, M10 (920.011.01) Draw out the axle from the fork and wheel. Remove the wheel by an easy pull downwards from the forks. Caution, while removing the wheel the left side spacer washer will fall out! During the assembly process put the spacer washer between the brake rotor and brake caliper mount plate and the right side distance spacer between the wheel and right fork (315.011.00). Return the brake pads with the spring and tighten up the axle nut. Perform the basic brake adjusting. Double check your work. This is important!

## REMOVE AND REPLACE THE REAR WHEEL - FIG. 5

Remove the rear wheel axle nut. Loosen the nut on the rear caliper anchor plate. Remove the two wheel adjustor plate nuts. (M6) Move the wheel forward and remove the chain. Safely (hold) keep the rear wheel from falling out while pulling out the axle. Caution, note the location of both spacer tubes and one spacer washer (between caliper mount plate and rotor) while removing wheel. When refitting the wheel, make sure to slide the brake rotor into the caliper between the pads. Hold the wheel in place and fit the wheel spacers in proper order. Insert the spacer washer between the caliper plate and the brake rotor and on the both sides place the axle spacers at the appropriate time during assembly. Adjust chain tension and tighten axle nut. Tighten the caliper holder plate nut and set and tighten both chain adjustor plate M6 nuts. At this time check the brake operation. Recheck all your work. This is important!

## PINION EXCHANGE: FIG. 6

First dismantle the front lining and chain guard. Loosen the nut of rear wheel axle and the nut of chain tightener, remove chain. Insert carefully a larger screwdriver or steel rod into the hole of clutch drum, Fig. 6, to avoid a turning over the clutch drum releasing the pinion. Using the socket wrench size 14 mm, release the new pinion to carried out by reverse way.

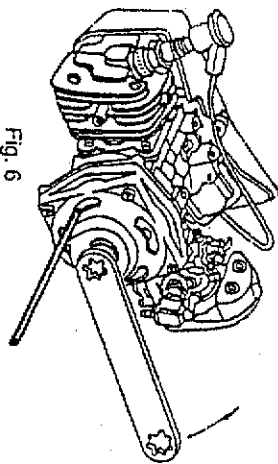

Fig. 6