

Two Year Limited Warranty on Battery Equalizers

WARRANTIES AND REMEDIES. Seller warrants that, at the time of shipment, the Products manufactured and sold by it hereunder will be free from defects in materials and workmanship. Seller's obligations and Buyer's remedies under this Warranty are limited to, at Seller's election, replacing or issuing an appropriate credit (the amount of said credit to be determined by Seller) for any Products or parts thereof which are demonstrated, to Seller's reasonable satisfaction, to have been defective at the time of shipment. Defective conditions in the Products caused by Buyer, third parties, acts of God, accidents, abnormal use or stress of any other matters unrelated to Seller and beyond its reasonable control are specifically excluded from coverage under this Warranty. **Should Product exhibit any indications of: (a) incorrect connection, (b) excessive voltage, (c) tampering with the enclosure, (d) exposure to adverse environment – including battery chemicals, (e) or any other condition inconsistent with normal use, this warranty is null and void. Product contains electronics that, upon inspection, may quickly identify incorrect installation.**

Seller's obligations, and Buyer's remedies, under this Warranty shall terminate two years after the date of shipment of the Products to Buyer.

THE FOREGOING WARRANTY IS EXCLUSIVE AND IS GIVEN AND ACCEPTED IN LIEU OF ANY AND ALL OTHER WARRANTIES, EXPRESS OR IMPLIED, INCLUDING, WITHOUT LIMITATION, THE IMPLIED WARRANTIES OF MERCHANTABILITY AND FITNESS FOR A PARTICULAR PURPOSE. IN NO EVENT SHALL SELLER BE LIABLE FOR INDIRECT, INCIDENTAL, SPECIAL OR CONSEQUENTIAL DAMAGES. THE LIABILITY OF SELLER UNDER THIS WARRANTY SHALL NOT EXCEED THE PURCHASE PRICE OF PRODUCT PAID BY PURCHASER.

In the event that Buyer has a claim under this Warranty, Buyer should send the product postage prepaid with proof of purchase (such as sales receipt) within the warranty period to the authorized reseller where the product was purchased. In no event will Seller be liable for any packaging expenses, inspection costs or labor charges incurred by Buyer in connection with the processing of claims under this Warranty or the return of defective Products.

SmartSpark Energy Systems, Inc.
60 E. Hazelwood Dr, Champaign, IL 61820
217-344-6044
www.smartsparkenergy.com

Copyright © 2006 by SmartSpark Energy Systems, Inc.
All Rights Reserved

Document Version 1.2



BattEQ™ Battery Equalizer

LA-50-12V-4 Installation Manual

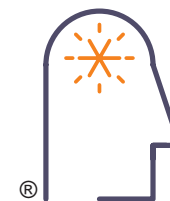

SmartSpark®
Energy
Systems

Energy middleware™ for tomorrow's resources

Description

The LA-50-12V-4 equalizer is designed to equalize four series-connected 12 volt lead acid batteries. It is sized for batteries with rated capacities up to 50 A-hr.

Installation

Installation is performed by wiring the leads from the equalizer to the batteries as shown in the figure. Care must be taken to ensure proper wiring. The equalizer should be located as close to the batteries as practical and excess lead lengths should be trimmed off.

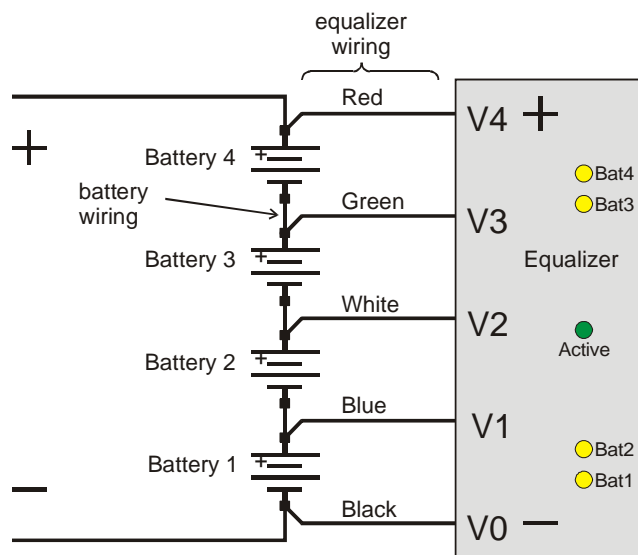

Equalizer – Battery Connection

There are five leads (10 AWG) from the equalizer to the batteries. After the leads are trimmed to the proper length, they should be connected to the batteries as shown in the figure. Start with lead V0 at the negative terminal and wire the leads sequentially, finishing with lead V4. Ensure that unconnected wires do not touch any metal, including the chassis of the vehicle, during installation. A small spark may be observed as each connection is made. This is caused by the equalizer capacitors being charged, and is normal.

WARNING: It is critical that the leads be connected properly to the battery terminals. Incorrect wiring will result in failure of the equalizer and may result in high currents drawn from the battery terminals.

Operation

Normal Operation: The equalizer is set to operate automatically when connected to the batteries. Normal operation is indicated by the EQ Active LED blinking once about every five seconds.

Mismatched Batteries: A blink pattern of five rapid blinks indicates the equalizer is not switching due to batteries that are too mismatched to equalize safely.

Weak Batteries: If the equalizer notes that a particular battery is weak compared to the other batteries in the string, it will turn on a LED corresponding to the weak battery. This detection will most likely happen during a full charge or discharge. A battery LED which is on indicates that the particular battery should be checked and monitored. The LED will remain on for 4 hours and will then reset itself.

Inactive Batteries: If the battery pack has not been charged in over a week, the equalizer will enter standby mode, turning off the equalizer to save power draw on the batteries. The equalizer will automatically turn back on when the pack is charged beyond 52.8 volts. The ACTIVE LED does not blink during this mode.

Removal

To uninstall the equalizer, simply reverse the process described above for installation.